



## MULTI-FUNCTION JOYSTICK



46701802

*Software rel. 2.3.X*

INSTALLATION, USE AND MAINTENANCE

---

## LEGEND OF SYMBOLS

---

 = Generic danger

 = Warning

**Object Pool** = Application that manages the equipment, loaded on the Virtual Terminal

---

---

## SUMMARY

---

<b>1</b>	<b>Risks and protections before assembly .....</b>	<b>3</b>
<b>2</b>	<b>Intended use .....</b>	<b>3</b>
<b>3</b>	<b>Precautions.....</b>	<b>3</b>
<b>4</b>	<b>Package content.....</b>	<b>3</b>
<b>5</b>	<b>Overall dimensions and fastening.....</b>	<b>4</b>
<b>6</b>	<b>Wiring connections.....</b>	<b>5</b>
6.1	General precautions for a correct harness position.....	5
6.2	Wiring harness connection .....	5
<b>7</b>	<b>Using the keys.....</b>	<b>6</b>
7.1	Quick function list consultation (long press <b>P2</b> ).....	6
<b>8</b>	<b>Switching on.....</b>	<b>7</b>
<b>9</b>	<b>Indications: LEDs and vibrations - ISOBUS MODE .....</b>	<b>7</b>
<b>10</b>	<b>Object pool .....</b>	<b>8</b>
10.1	"OBJECT POOL" loading.....	8
10.2	ISOBUS .....	8
10.3	Functions assignment.....	9
10.3.1	Automatically loading ARAG functions.....	9
10.3.2	Customizing functions assignment .....	9
10.3.3	ARAG default functions.....	10
10.3.4	Key map.....	11
10.4	Test keys.....	13
10.5	Versions .....	13
10.6	Registration .....	14
10.7	Settings.....	14
<b>11</b>	<b>Technical data .....</b>	<b>15</b>
<b>12</b>	<b>End-of-life disposal.....</b>	<b>15</b>
<b>13</b>	<b>Warranty terms.....</b>	<b>15</b>
<b>14</b>	<b>DECLARATION OF CONFORMITY .....</b>	<b>15</b>

*This manual is an integral part of the equipment to which it refers and must accompany the equipment in case of sale or change of ownership. Keep it for any future reference; ARAG reserves the right to modify product specifications and instructions at any moment and without notice.*

---

## • **MANUAL FOREWORD AND USE**

---

This manual provides instructions to assemble, connect and set the EXPLORER multi-function joystick.  
Any other information is provided in specific sheets to be used exclusively by the installer, containing specific information of each computer model.

---

## • **MANUAL USE MODES**

---

The section of this manual dedicated to the installation contains information for installers. For this reason we have used technical terms without providing explanations which would be necessary for end users only.

**THE INSTALLATION MUST BE CARRIED OUT BY AUTHORIZED AND SKILLED PERSONNEL ONLY. THE MANUFACTURER IS NOT RESPONSIBLE FOR ANY OPERATION SPECIFIED IN THIS MANUAL CARRIED OUT BY UNAUTHORIZED OR UNSKILLED PERSONNEL.**

---

## • **RESPONSIBILITY**

---

The installer must carry out workmanlike installations and ensure to the end user the perfect operation of the whole system both with ARAG components only and other brands' components.

ARAG always recommends using its components to install control systems.

The installer will be held responsible for any malfunction if he decides to use other brands' components even without actually changing the system parts or harness.

The compatibility check with components and accessories of other manufacturers shall be carried out by the installer.

If the computer or the ARAG components installed together with other brands' components get damaged because of what stated above, no direct or indirect warranty will be provided.

---

## **1 RISKS AND PROTECTIONS BEFORE ASSEMBLY**

---

All installation works must be done with battery disconnected, using suitable tools and any individual protection equipment deemed necessary.

 Use **ONLY** clean water for treatment tests and simulations: using chemicals during simulated treatment runs can seriously injure persons in the vicinity.

---

## **2 INTENDED USE**

---

EXPLORER is a multi-function joystick that, suitably configured by the computer in your possession, allows you to manage the main functions of a crop sprayer (spraying and hydraulics) directly from the handgrip.

**This device is designed to work on agricultural machinery for spraying and crop spraying applications.**

**The machine is designed and built in compliance with EN ISO 14982 standard (Electromagnetic compatibility - Forestry and farming machines), harmonized with 2014/30/EU Directive.**

---

## **3 PRECAUTIONS**

---

-  • Do not aim water jets at the equipment.  
• Do not use solvents or fuel to clean the case outer surface.  
• Do not clean equipment with direct water jets.  
• Comply with the specified rated power voltage (12 Vdc).  
• In case of voltaic arc welding, remove connectors from the device and disconnect the power cables.  
• Only use ARAG genuine spare parts and accessories.

---

## **4 PACKAGE CONTENT**

---

The table below indicates the components that you will find in the package.



- 1 Explorer Joystick
- 2 Sleeve and locking nut
- 3 ISOBUS adapter cable

Fig. 1

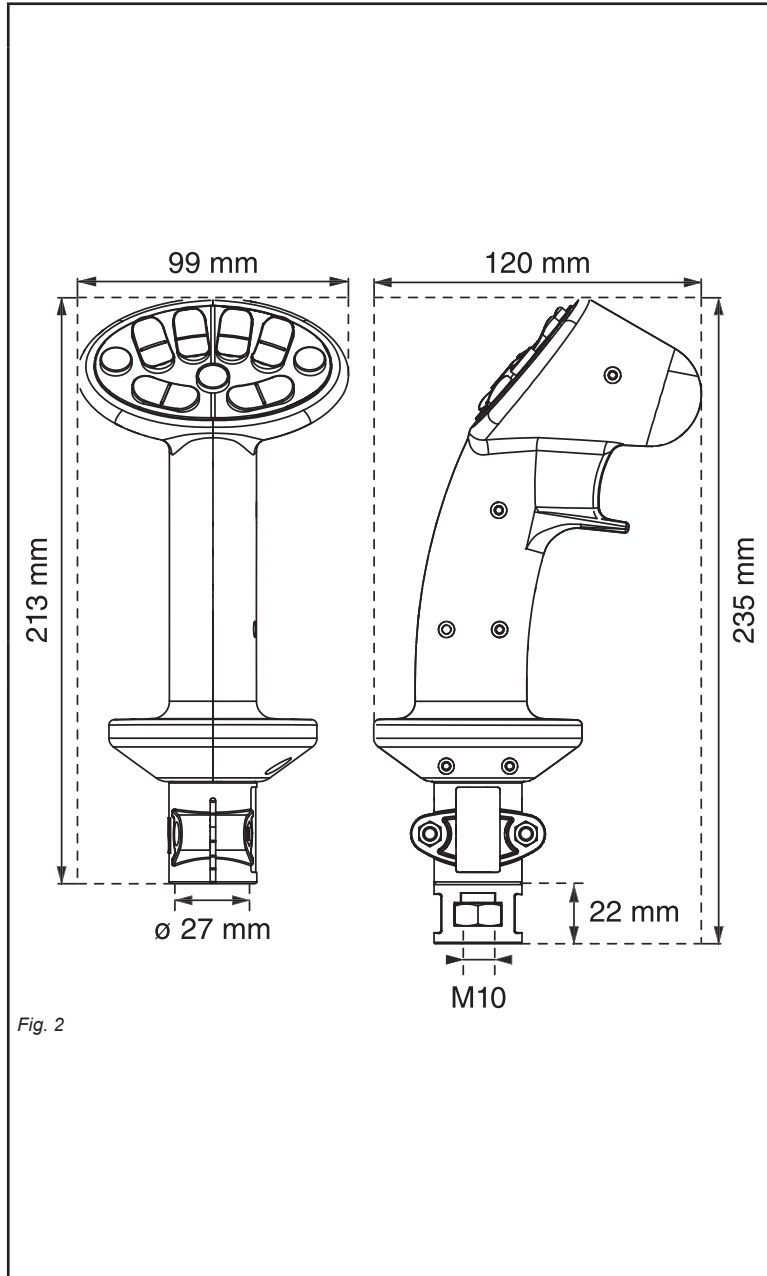

CLAMP FASTENING

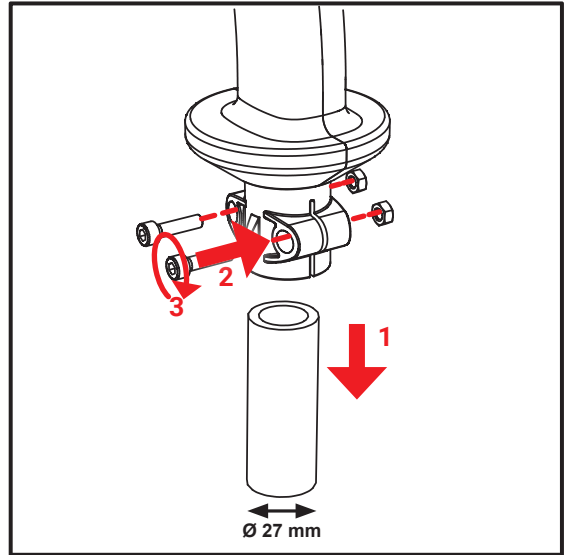

Fig. 3

THREAD FASTENING

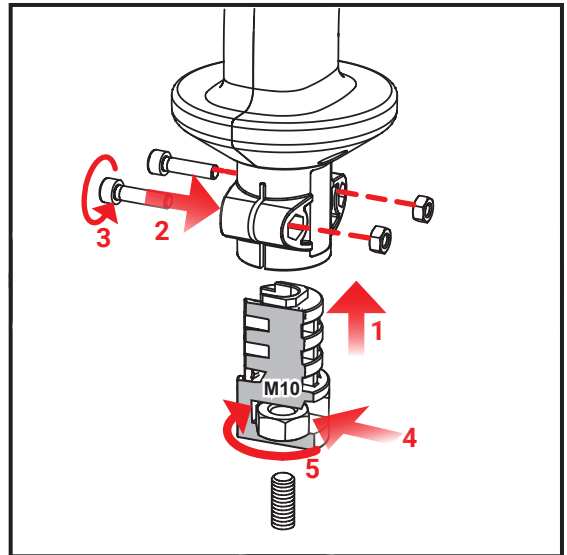

Fig. 4

## 6 WIRING CONNECTIONS

- Use only the cables provided with the ARAG devices.
- Take care not to break, pull, tear or cut the cables.
- Use of unsuitable cables not provided by ARAG automatically voids the warranty.
- ARAG is not liable for any damage to the equipment, persons or animals caused by failure to observe the above instructions.

### 6.1 General precautions for a correct harness position

- **Securing the cables:**
  - fasten the harnesses so that they do not interfere with moving parts;
  - route the harnesses so that they cannot be damaged or broken by machine movements or twisting.
- **Fitting the cables to the connection points:**
  - Do not force the connectors by pushing too hard or bending them: the contacts may be damaged and device operation may be compromised.



Use **ONLY** the cables and accessories indicated in the catalog, having technical features suitable for the use to be made of them.

### 6.2 Wiring harness connection



**CAUTION: A-net and ISOBUS models of the joystick cannot be replaced with each other. They use the same connector but are equipped with two different software programs.**

Connect the connector of the joystick to the connector of the relevant harness; after making sure it is correctly inserted, press until it locks.

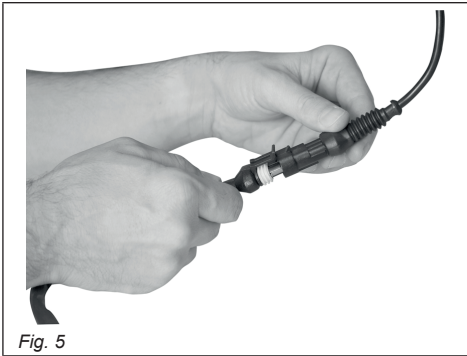

Fig. 5

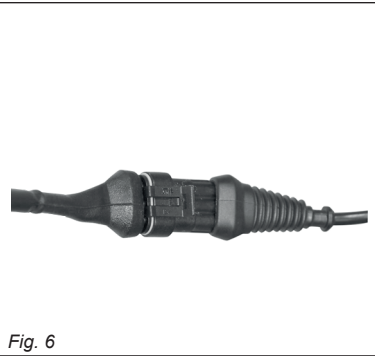

Fig. 6

- **ISOBUS adapter cable (supplied only for ISOBUS version code 46701802)**

Connect the joystick connector to the adapter; join the other end with the **IN-CAB CONNECTOR**; after ensuring correct insertion, turn the ring nut clockwise until it locks.

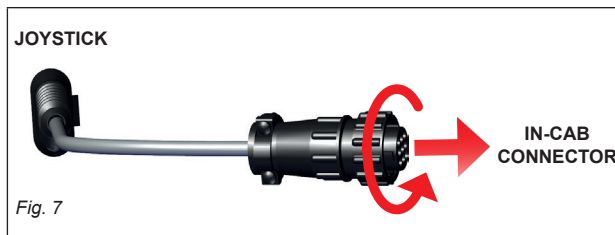

Fig. 7

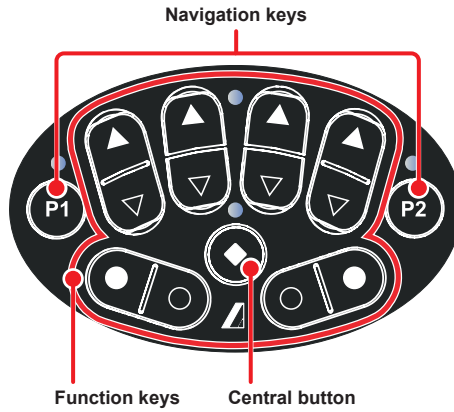

Fig. 8

When the joystick is switched on, the functions of the "Main" page (P0) are active; use keys **P1** and **P2** to access the functions of the other pages (Fig. 9).

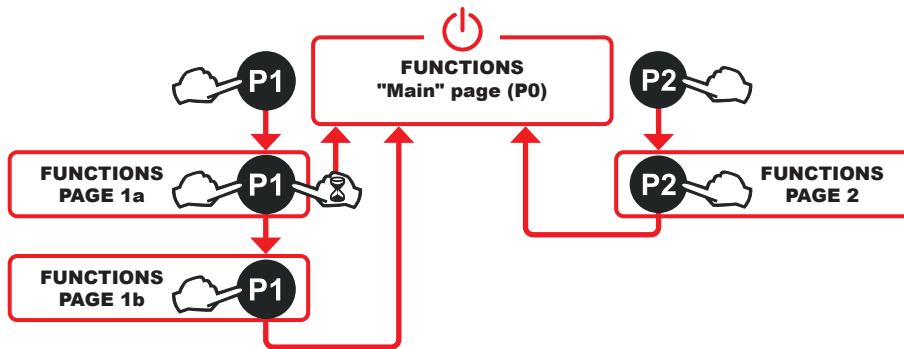
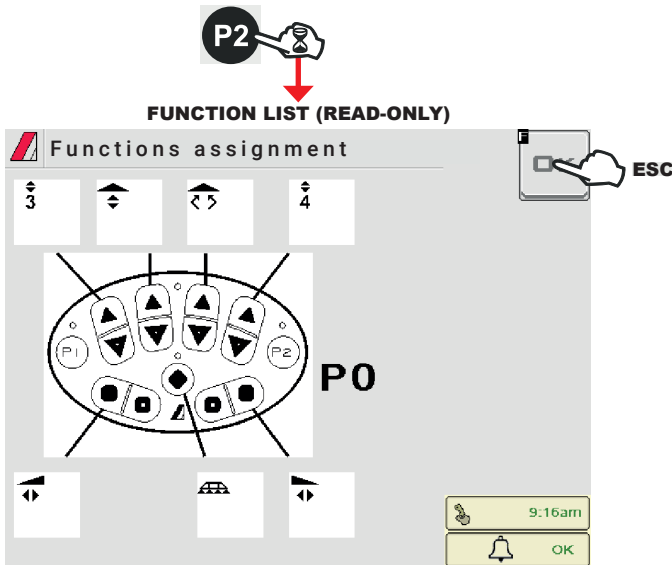

Fig. 9

7.1 Quick function list consultation (long press P2)

Allows viewing the page for assigning functions to the keys of the EXPLORER joystick.

**Press and hold the P2 button to access the assignment summary page directly.**  
This page is read-only.



## 8 SWITCHING ON

### • Starting the device

First, LED **L2** (Fig. 10) indicates the operating mode of the device.

**1 periodical blink of LED L2:** start in A-NET mode.

**2 periodical blinks of LED L2:** start in ISOBUS mode.

### • Function test

After start-up, the joystick performs a function test as follows:

simultaneous switching on of all LEDs, backlighting of the keyboard and 1 long vibration.

The device accesses the functions of the "Main" page and makes the following indications operational.

**Consult the paragraph "Indications: LEDs and vibrations" relative to the model in your possession.**

## 9 INDICATIONS: LEDs AND VIBRATIONS - ISOBUS MODE

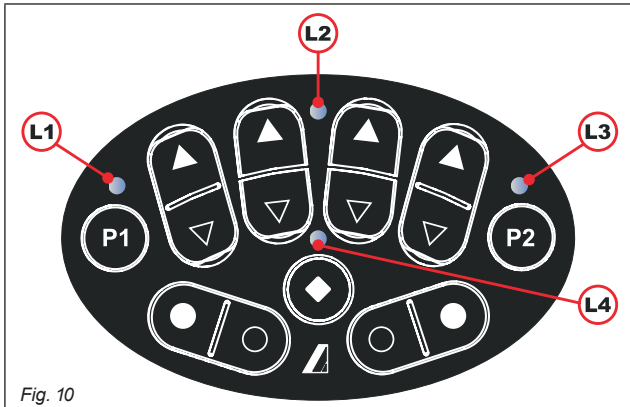

Fig. 10

• Pressing active keys  
When each button is pressed the device vibrates (1 short vibration).

LED No.	LED STATUS	VIBRATION
<b>L1: PAGES 1 / 1 bis</b>		
<b>L1</b>	- steady on: page 1 ONLINE	1 vibration + 1 pause
	- regular blinking: page 1 bis ONLINE	1 vibration + 1 pause
	- off: Main page ONLINE	none
	- off: page 2 ONLINE	2 vibrations + 1 pause
<b>L2: ALARMS INDICATION LED</b>		
<b>L2</b>	- off: Object Pool* correctly loaded, correct ISOBUS operation	none
	- 1 periodic blink: initialization	none
	- 2 periodic blinks: Object Pool loading* in progress	none
	- 3 periodic blinks: Object Pool loading* failed	none
- 4 periodic blinks: corrupted memory, formatting in progress	none	
<b>L3: PAGE 2</b>		
<b>L3</b>	- steady on: page 2 ONLINE	2 vibrations + 1 pause
	- off: Main page ONLINE	none
	- off: page 1 / 1 bis ONLINE	1 vibration + 1 pause
<b>L4: CENTRAL BUTTON STATUS</b>		
<b>L4</b>	- steady on: associated function ON	none
	- off: associated function OFF	none

#### KEY:

- **regular blink** = constant blinking

- **periodical blink** = series of blinks interrupted by a pause

\*OBJECT POOL: joystick software loaded on Virtual Terminal

## 10 OBJECT POOL



Images and the relevant description texts contained in this manual are given as a reference as they can vary depending on the *Virtual Terminal* used. If the descriptions do not correspond to the text displayed in your *Virtual Terminal*, refer to the manual attached to the latter.

### 10.1 "OBJECT POOL" loading

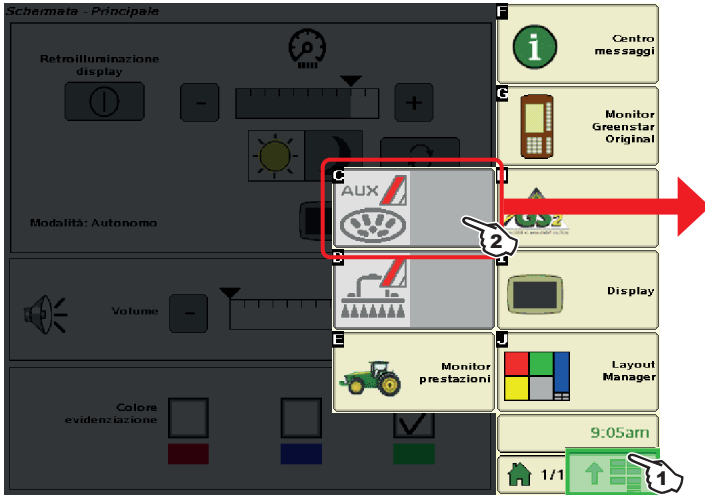

Fig. 11

- 1 Press to display the Object Pool selection page (C: Auxiliary Input Object Pool).
- 2 Press to enter the main screen.

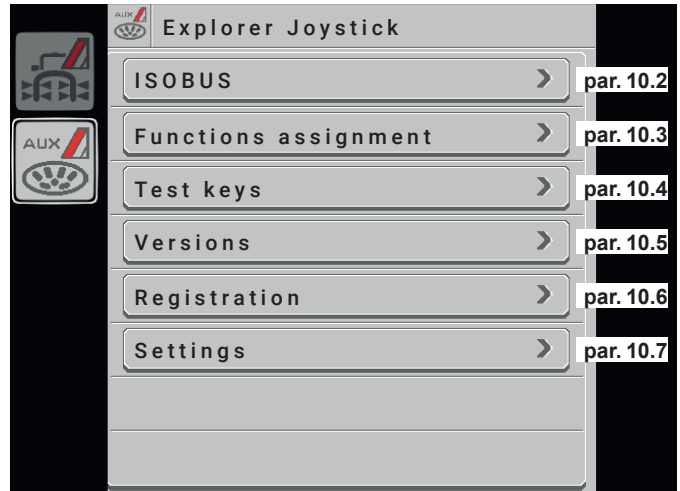

Fig. 12

par. 10.2  
par. 10.3  
par. 10.4  
par. 10.5  
par. 10.6  
par. 10.7

### 10.2 ISOBUS

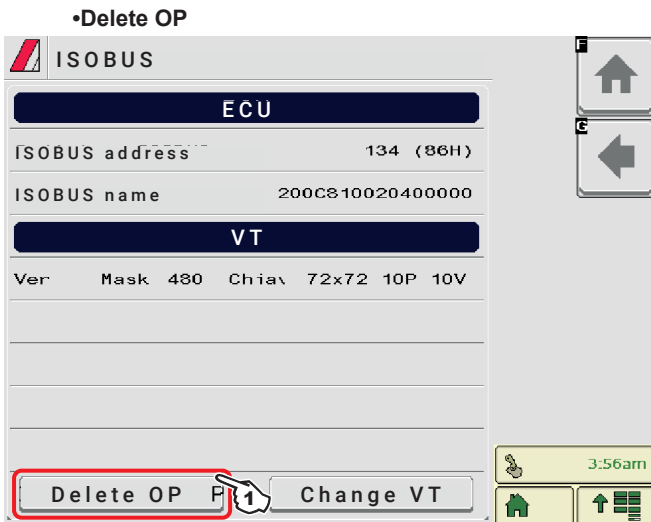

Fig. 13

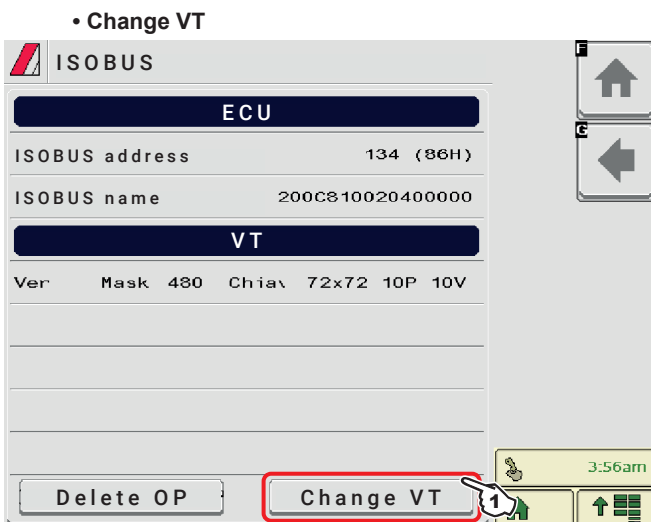

Fig. 15



Fig. 14

Use this function **ONLY** when some components of the Object Pool have not been loaded properly; after deletion, the Virtual Terminal reloads the entire application.

- 1 Press to delete the Object Pool.
- 2 Confirm with .



Fig. 16

In case of more than one VT on the tractor, this function allows moving the OP from one monitor to the other.

**NOTE:** The auxiliary input devices like the Joystick can be loaded **ONLY** on VT with INSTANCE 1 (address on the communication BUS).

- 1 Press to change setting.
- 2 Confirm with .



### 10.3 Functions assignment

To use the Joystick functions, it is necessary to assign keys to functions, which can be done automatically or individually.

#### 10.3.1 Automatically loading ARAG functions

The EXPLORER joystick connected to an ARAG ECU allows the automatic implementation of the preset ARAG functions ("The functions described in this page cannot be changed." on page 10.  
After the first configuration the Virtual Terminal may ask for the auxiliary joystick to be enabled.

#### 10.3.2 Customizing functions assignment

The device allows customized functions assignment via two modes:



 CAUTION: THE **Single** mode MAY BE INCOMPATIBLE WITH THE ECU TO WHICH THE JOYSTICK IS CONNECTED. CHECK THAT THE ECU IN YOUR POSSESSION SUPPORTS THIS MODE.

#### SINGLE MODE ENABLING

Allows you to assign functions to **each part** of the button .

Enable single mode:

- Within the Object Pool of the EXPLORER Joystick in the **Settings** menu choose the **Single** option (Fig. 18).

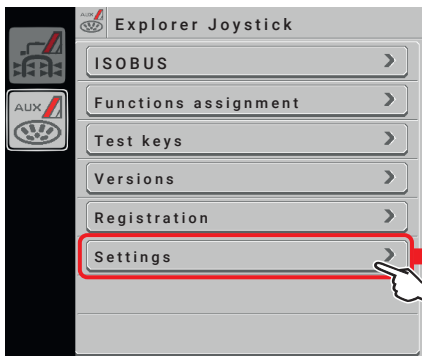

Fig. 17

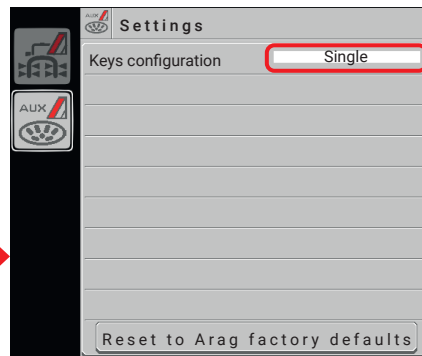

Fig. 18

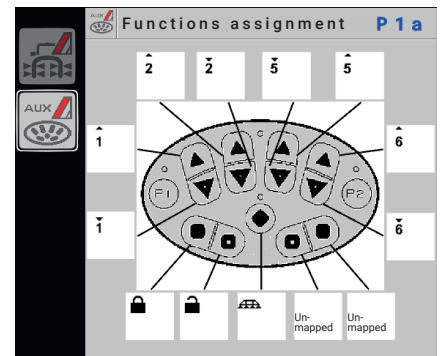



Fig. 19

Now it is possible to assign a function for **each individual button** (e.g. opening a valve).

#### DUAL MODE ENABLING

Allows you to assign functions to each button .

Enable dual mode:

- Within the Object Pool of the EXPLORER Joystick in the **Settings** menu choose the **Dual** option (Fig. 21).

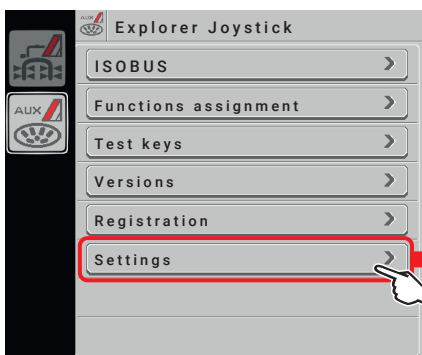

Fig. 20

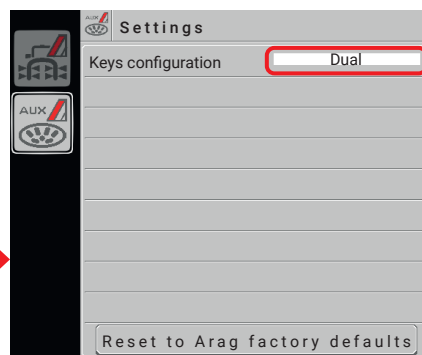

Fig. 21

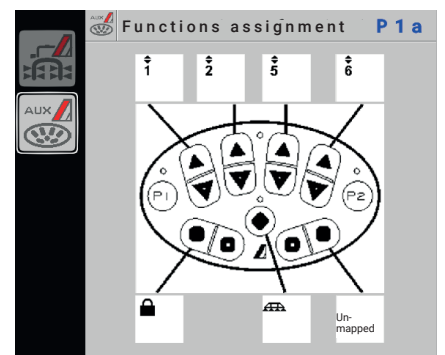



Fig. 22

When assigning a function automatically **both individual buttons** are programmed (e.g. opening and closing a valve).

CONTINUES >>>

 The functions described below are illustrative.  
 The following contents may NOT be updated and may differ from the product in your possession.  
 To know the default ARAG assignments corresponding to your application, please refer to the relevant manual.  
 The functions described in this page cannot be changed.

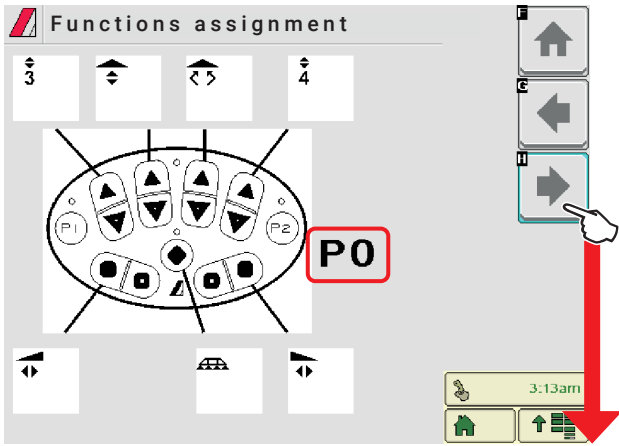

Fig. 23

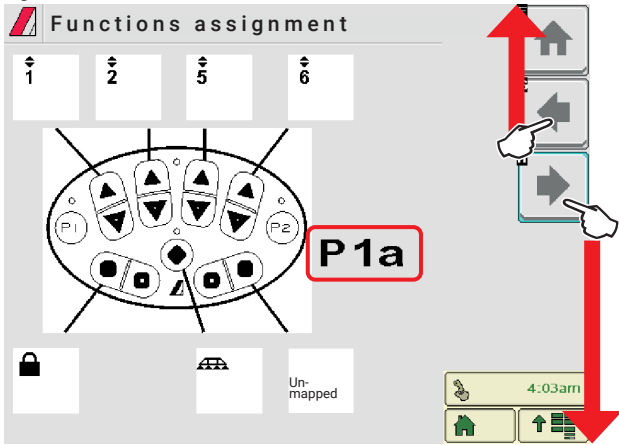
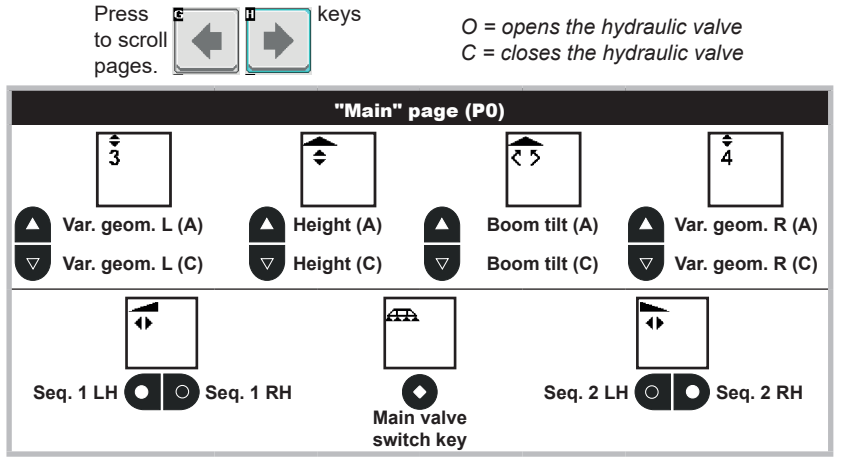

Fig. 24

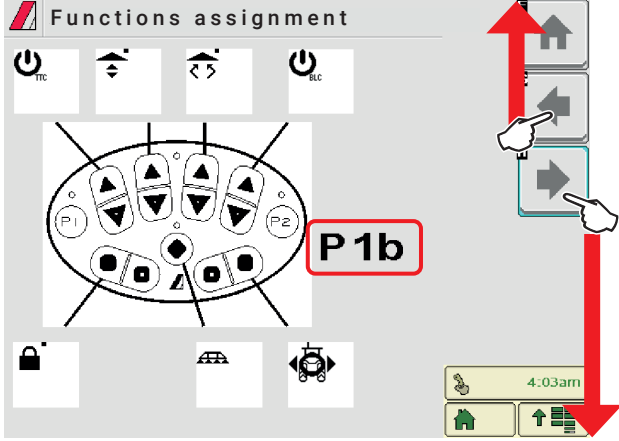
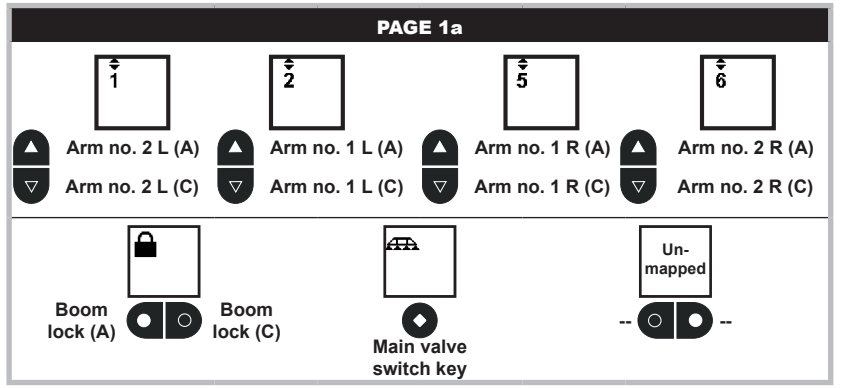

Fig. 25

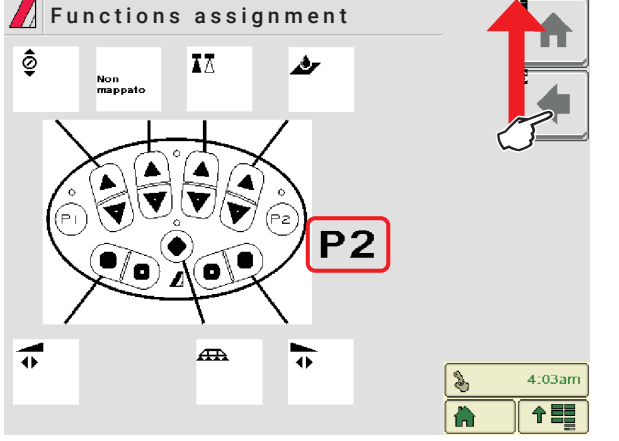
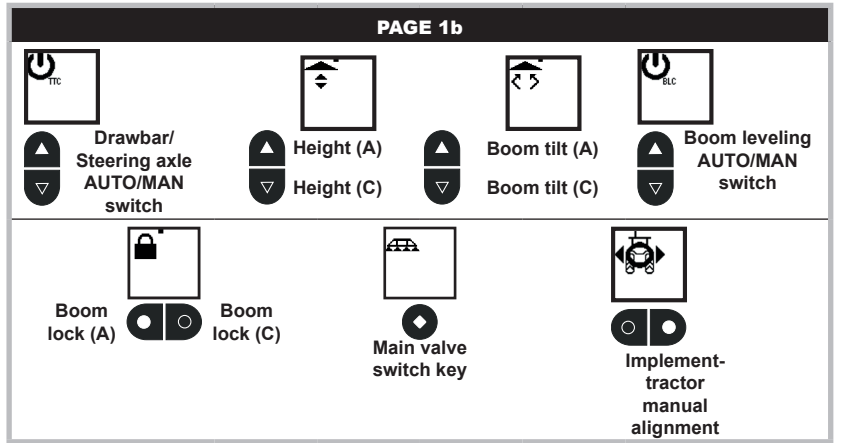
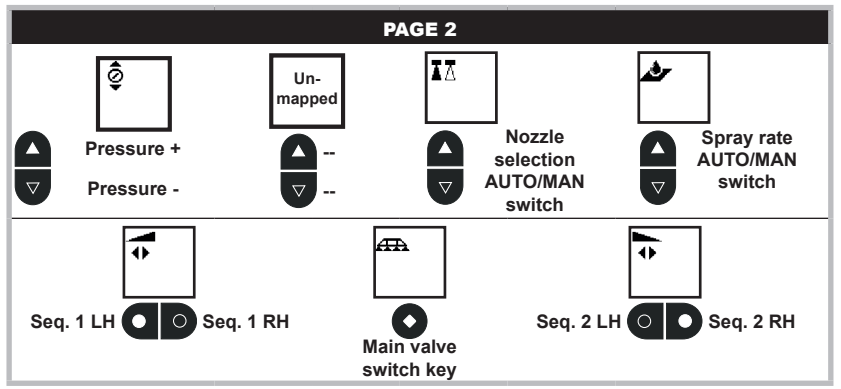

Fig. 26



The following pages contain the mapping of the buttons in **Single** or **Dual** mode.

CONTINUES >>>

The KEY MAP below is useful to manually assign the functions to the joystick keys in Single mode.

**"Main" page (P0)**

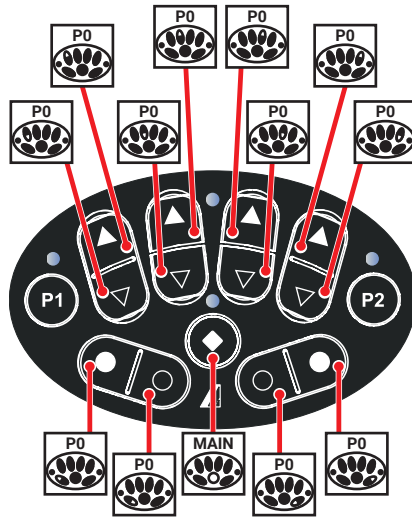

**PAGE 1a**

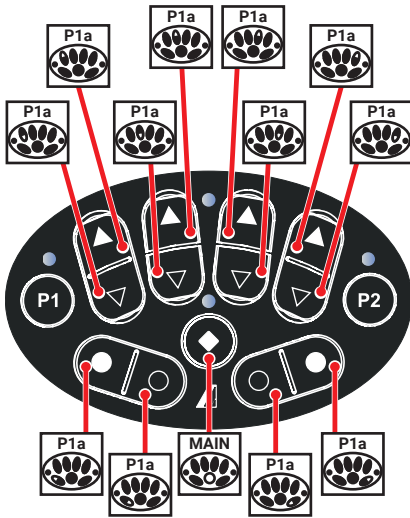

**PAGE 1b**

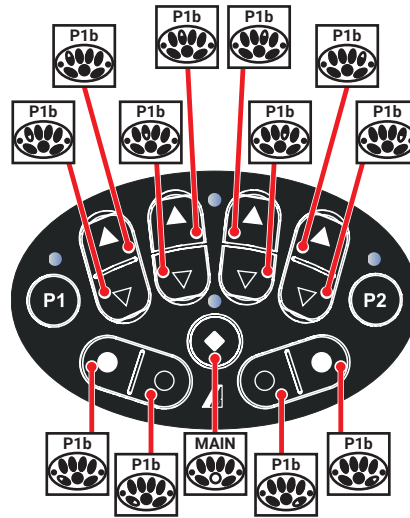

**PAGE 2**

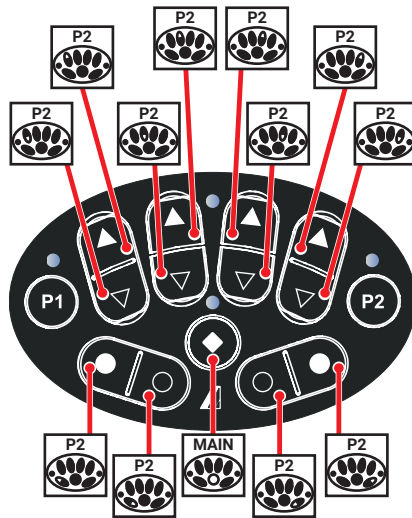

The following page contains the mapping of the keys in **Dual** mode.

CONTINUES >>>

The KEY MAP below is useful to manually assign the functions to the joystick keys in Dual mode.

### "Main" page (P0)

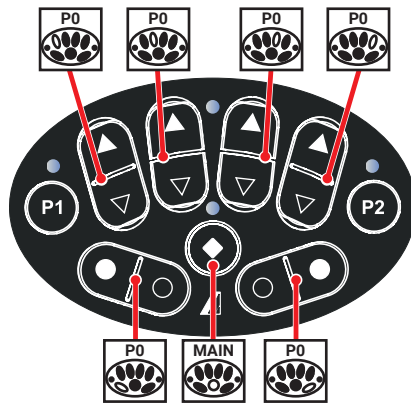

### PAGE 1a

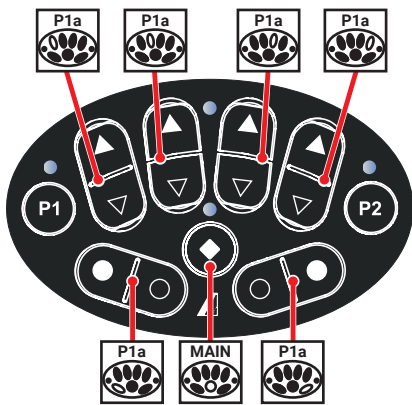

### PAGE 1b

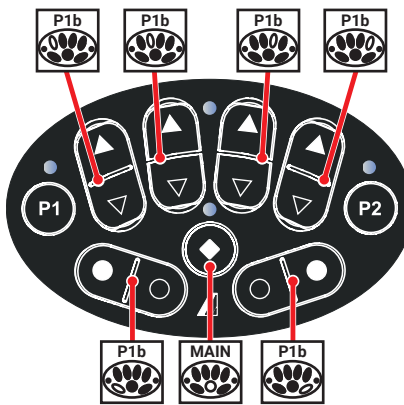

### PAGE 2

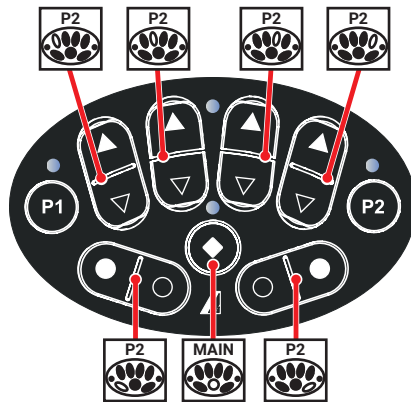

## 10.4 Test keys

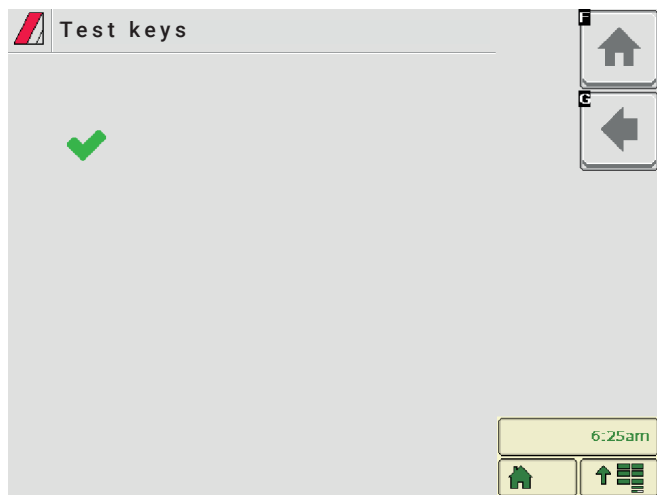

Press the keys one at a time: if operation is correct, the Virtual Terminal display shows a tick sign.

Fig. 27

## 10.5 Versions

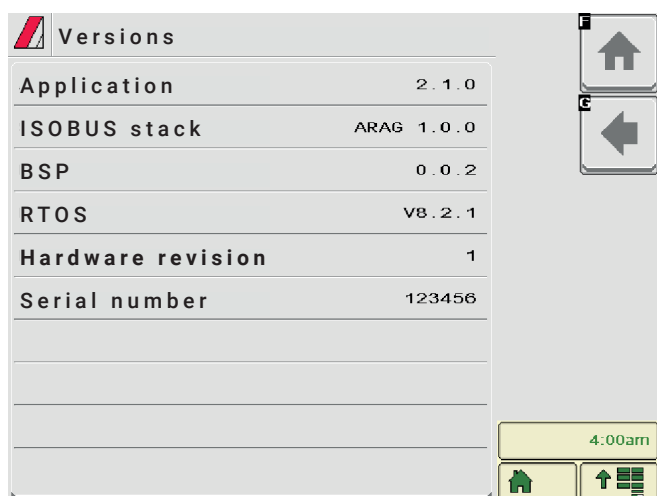

It displays the versions of the currently used system.

Fig. 28

CONTINUES >>>

## 10.6 Registration

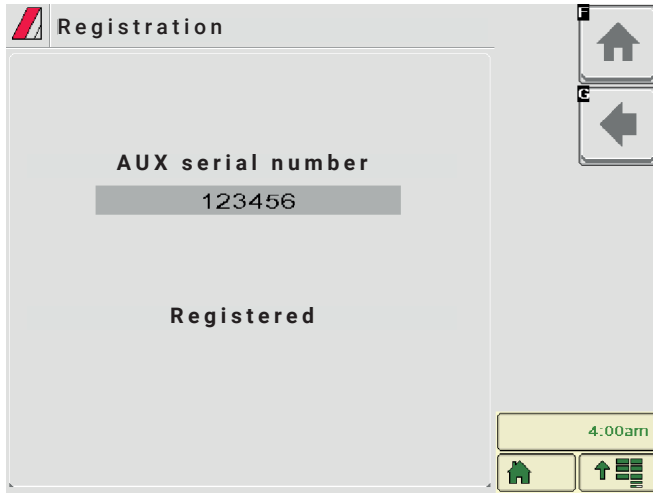

Fig. 29

It displays the serial number of the Auxiliary Input and checks device registration.

**Registered** = it indicates that registration is correct.

## 10.7 Settings



Fig. 30

### Keys configuration

- Allows selecting the type (**Single** or **Dual**) used to assign functions to the Joystick keys. The two modes are described in paragraph 10.3.2.

### Reset to Arag factory defaults

- Allows restoring the device to factory default settings.

---

**11 TECHNICAL DATA**

---

Power supply voltage	9 ÷ 16 Vdc
Operating temperature	-20°C / +70°C -4 °F ÷ +158 °F
Storage temperature	-40 °C ÷ +85 °C -40 °F ÷ +185 °F
Protection against polarity inversion	✓
Protection against short-circuit	✓
Protection rating	IP65

---

**12 END-OF-LIFE DISPOSAL**

---

Dispose of the system in compliance with the established legislation in the country of use.

---

**13 WARRANTY TERMS**

---

1. ARAG s.r.l. guarantees this apparatus for a period of 360 days (1 year) from the date of sale to the client user (date of the goods delivery note).  
The components of the apparatus, that in the unappealable opinion of ARAG are faulty due to an original defect in the material or production process, will be repaired or replaced free of charge at the nearest Assistance Center operating at the moment the request for intervention is made. The following costs are excluded:
  - disassembly and reassembly of the apparatus from the original system;
  - transport of the apparatus to the Assistance Center.
2. The following are not covered by the guarantee:
  - damage caused by transport (scratches, dents and similar);
  - damage due to incorrect installation or to faults originating from insufficient or inadequate characteristics of the electrical system, or to alterations resulting from environmental, climatic or other conditions;
  - damage due to the use of unsuitable chemical products, for spraying, watering, weedkilling or any other crop treatment, that may damage the apparatus;
  - malfunctioning caused by negligence, mishandling, lack of know-how, repairs or modifications carried out by unauthorized personnel;
  - incorrect installation and regulation;
  - damage or malfunction caused by the lack of ordinary maintenance, such as cleaning of filters, nozzles, etc.;
  - anything that can be considered to be normal wear and tear;
3. Repairing the apparatus will be carried out within time limits compatible with the organizational needs of the Assistance Center.  
No guarantee conditions will be recognized for those units or components that have not been previously washed and cleaned to remove residue of the products used;
4. Repairs carried out under guarantee are guaranteed for one year (360 days) from the replacement or repair date.
5. ARAG will not recognize any further expressed or intended guarantees, apart from those listed here.  
No representative or retailer is authorized to take on any other responsibility relative to ARAG products.  
The period of the guarantees recognized by law, including the commercial guarantees and allowances for special purposes are limited, in length of time, to the validities given here.  
In no case will ARAG recognize loss of profits, either direct, indirect, special or subsequent to any damage.
6. The parts replaced under guarantee remain the property of ARAG.
7. All safety information present in the sales documents regarding limits in use, performance and product characteristics must be transferred to the end user as a responsibility of the purchaser.
8. Any controversy must be presented to the Reggio Emilia Law Court.

---

**14 DECLARATION OF CONFORMITY**

---

The declaration of conformity is available at the website [www.aragnet.com](http://www.aragnet.com), in the relevant section.

---

Only use genuine ARAG accessories or spare parts to make sure manufacturer guaranteed safety conditions are maintained in time.  
Always refer to the Internet address [www.aragnet.com](http://www.aragnet.com)

D20355\_GB-m01 12/2020



---

42048 RUBIERA (Reggio Emilia) - ITALY  
Via Palladio, 5/A  
Tel. +39 0522 622011  
Fax +39 0522 628944  
<http://www.aragnet.com>  
[info@aragnet.com](mailto:info@aragnet.com)